

KOFFERTRÄGER X RACK

Luggage rack X rack / Porte-bagages X rack / Portaequipajes X rack / Portapacchi X rack

Art.Nr: 30182-002

Für eine vollständige Montage der Ausrüstung, montieren Sie den Kofferträger X-Rack / light vor dem Topcase-Träger X-Rack.

For a full equip assembly, mount the luggage rack X-Rack / light before the Top case carrier X-Rack.

Pour un montage complet de l'équipement, montez d'abord le porte-bagages X-Rack / light avant le porte-top case X-Rack.

Para un montaje completo del equipamiento, monte primero el portaequipajes X-Rack / light antes del portaequipajes de maleta superior X-Rack.

Per un montaggio completo dell'equipaggiamento, montare il portapacchi X-Rack / light prima del portapacchi per bauletto X-Rack.

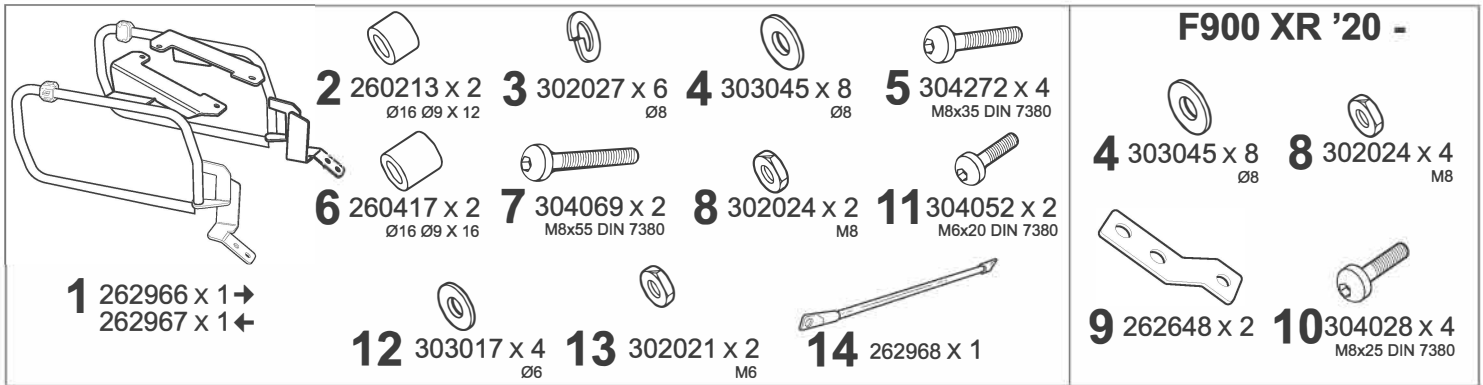

WARNING! ⚠

GB Do not fully tighten the screws until it is ensured that the KIT is correctly attached and aligned.

E No apretar los tornillos del todo hasta asegurarse que el KIT está correctamente colocado y alineado.

D Ziehen Sie die Schrauben nicht ganz fest, bevor Sie sich nicht vergewissert haben, dass der Bausatz korrekt eingestellt und ausgerichtet ist.

I Non stringere del tutto le viti fin tanto non si è sicuri che il kit è collocato correttamente e allineato.

F Ne pas serrer les vis avant d'être sûr que le KIT soit correctement positionné et ajusté.

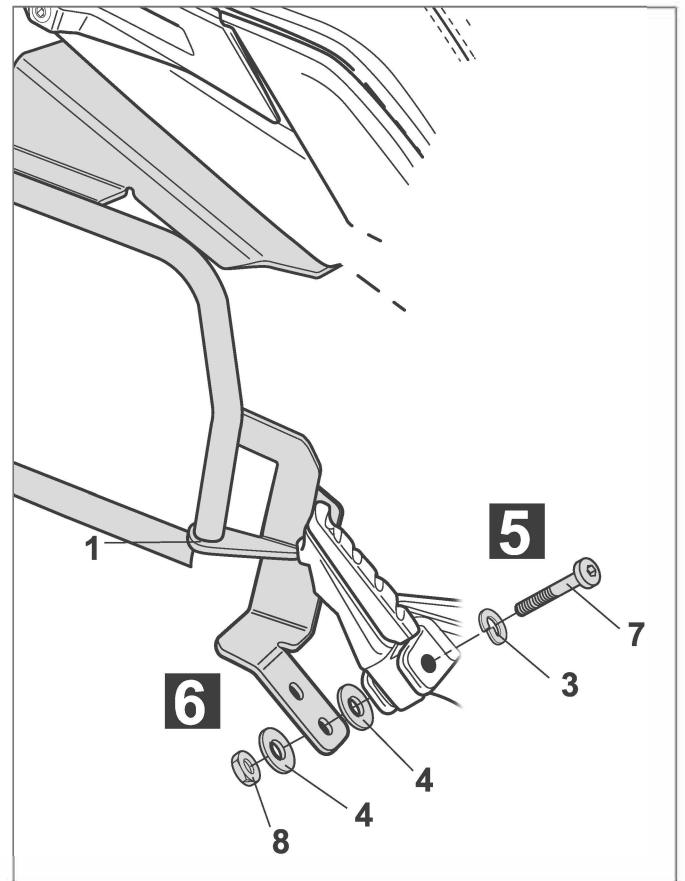
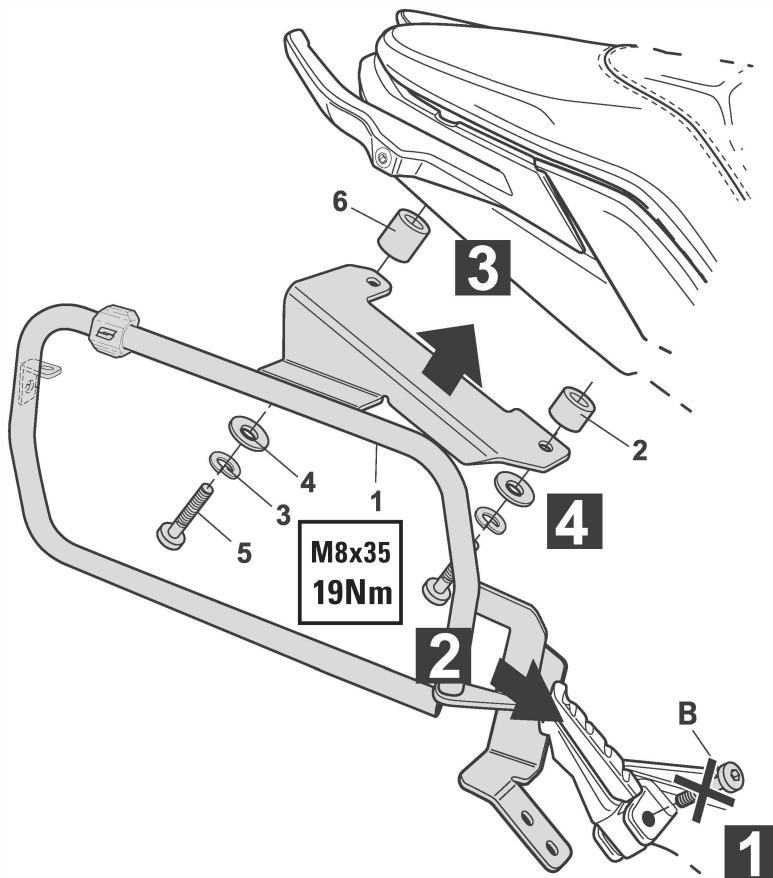

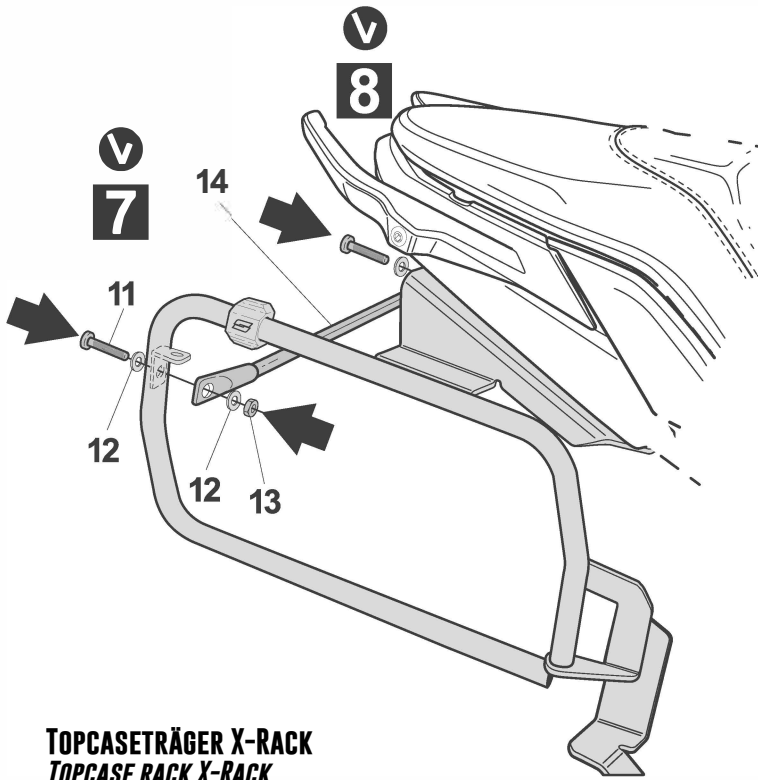

TOPCASETRÄGER X-RACK
TOPCASE RACK X-RACK
PORTE-BAGAGES SUPÉRIEUR X-RACK

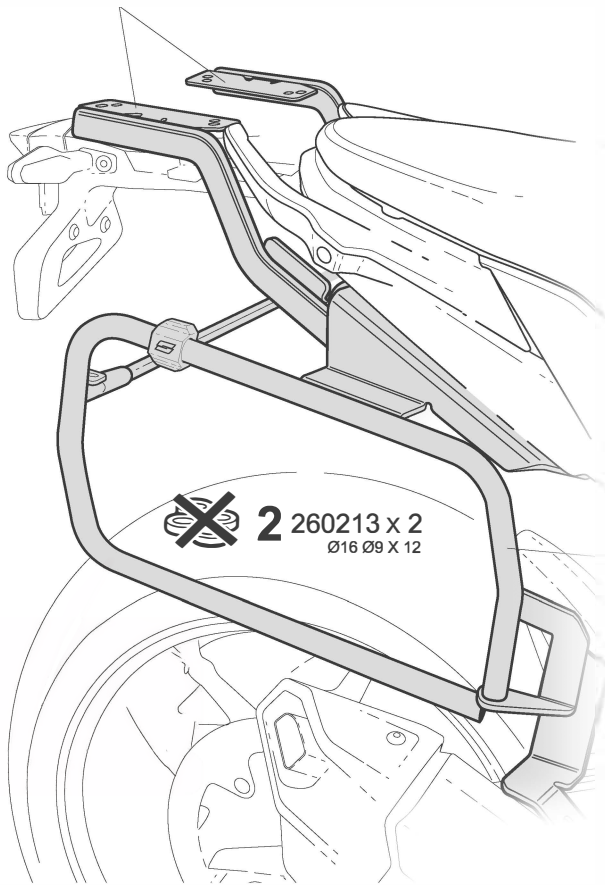

~~2~~ 260213 x 2
 Ø16 x 12

BMW F900 XR '20 -

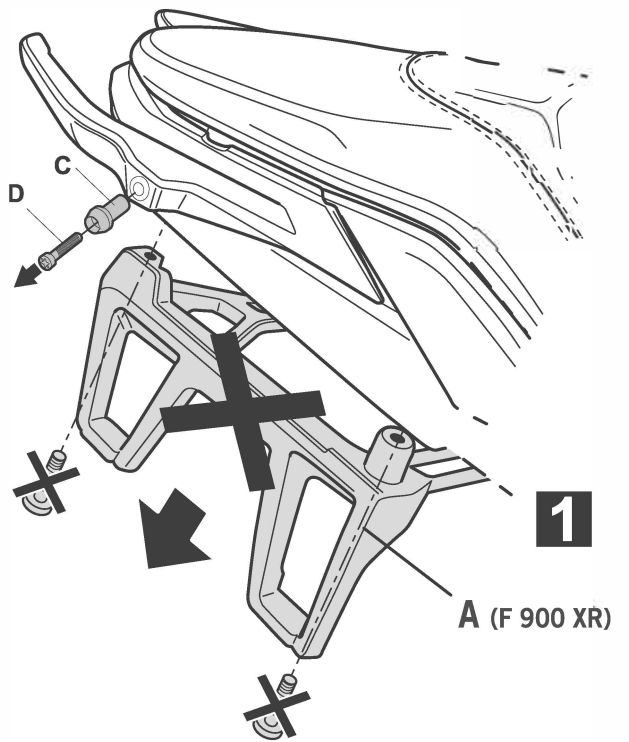

A (F 900 XR)

